

Built for Your



Industry



(a subsidiary of Bright Coop, Inc.)

built the way you want it for the way you use it!

35 Ton, "Paver Special" Lowboy
Model: VPVR49R16F35T Weight 17,800 lbs. Plus or Minus 3%



The 35 Ton Paver Special Lowboy was designed to allow the loading and unloading of equipment with minimal ground clearance. The bi-fold hydraulic assisted ramps allow a longer and gradual 10 degree approach to the dovetail and onto the lower deck. Capacity: 86,000 lb. GVWR.



Built for Your



Industry



(a subsidiary of Bright Coop, Inc.)

built the way you want it for the way you use it!

35 Ton, "Paver Special" Lowboy Model: VPVR49R16F35T

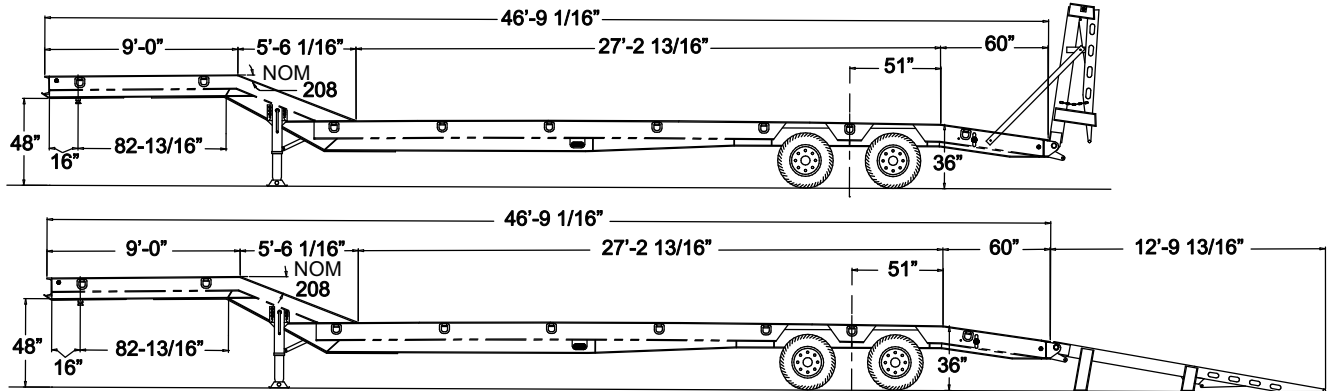

102" Wide Weight 17,800 lbs. Plus or Minus 3% Capacity: 86,000 lb. GVWR

Features:

- Mainframe..... 16" Fabricated main beams, 1/2" x 6" top flange and 3/4" x 6" bottom flange with 1/4" web welded on both sides. All flange and web material is high strength steel.
- Crossmembers... 8" x 6.5# Jr. I beam on 20" centers.
- Kingpin..... 2" SAE kingpin, 3/8" kingpin plate, 16" kingpin setting (standard).
- Siderails..... 10" x 15.3 # Structural channel; 8" x 8.5# structural channel on the neck.
- Suspension..... HUTCH® H9700T three point spring suspension with hi-arch heavy duty 3 leaf springs.
- Axles (2) 25,000 Lb., 5" round, 5/8" wall.
- Brakes 12-1/4" x 7", Type 30/30 brake chambers, outboard drums, Meritor WABCO® (2S/1M) ABS on one axle.
- Wheels..... 6.5 x 17.5, Steel 10 hole disc, stub piloted (color: white).
- Tires..... 255/70R x 17.5 Radials.
- Landing gear..... 2 speed gear with 62,500 lb. lift capacity; 200,000 lb. static capacity (standard).
- Finish..... Shotblasted and painted with a high solid polyurethane paint. colors: black or red (standard).
- Floor..... 2" Nominal oak (standard), 1/4" metal covering is standard over tandems areas.
- Lights..... 7-Way main receptacle, sealed wiring harness, rubber mounted LED lights. 3 Lights per side including mid-turn.
- Tandem..... Set at 131" from the rear of the dovetail.
- Dovetail..... 5ft. Long, floored with 2" nominal oak, 8° degree approach angle.
- Loading ramps.... 13 ft. Bi-fold hydraulic ramps, 10 degree approach angle, front: 20° degree rise to upper deck, 12-volt self contained hydraulic unit.
- D-rings..... 18 Total (4) 1" on upper deck, (14) 1" on rear deck.

Options:

- 15,000 Lb. hydraulic winch with 5/8" x 100' cable
- Hydraulic remote valve
- (2) Two remote ports and 12' remote cable for winch
- Weld on winches
- Fold out outriggers
- Width increase to 9'
- Longer and shorter lengths
- Between the beam tool box
- Epoxy or zinc-rich primer available
- Hydraulic assisted ramps

Viking Specialized Trailers, L.L.C.
1730 S.W. Stalling Dr., Suite 101
Nacogdoches, Texas 75964
(936) 564-8370 (844) 815-6210
Fax (936) 205-9171
www.vikingspzdtrailers.com