

**Built for Your**



**Industry**



(a subsidiary of Bright Coop, Inc.)

*built the way you want it for the way you use it!*

**Plantation 4 Bolster  
Model: V4B40PF**

**Weight 12,600 lbs. Plus or Minus 3%**



The New Viking Plantation 4- Bolster combines every manufacturing quality that makes up the viking name. Designed to haul a variety of harvested timber. Capacity: 80,000 lb. GVWR.  
Lightweight Capacity: 80,000 lb. GVWR

**Lightweight Plantation 4 Bolster  
Model: V4B40PFLW**

**Weight 11,375 lbs. Plus or Minus 3%**



**Shown with Options**

# Built for Your



# Industry



(a subsidiary of Bright Coop, Inc.)

*built the way you want it for the way you use it!*

## Plantation 4 Bolster

## Model: V4B40PF

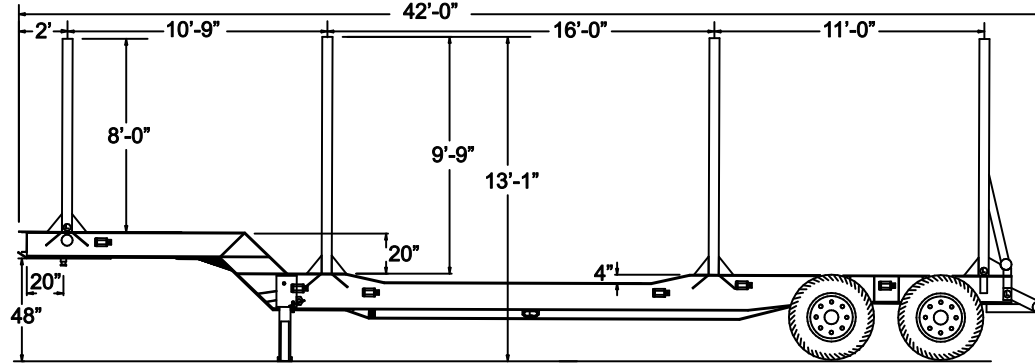

102" Wide Weight 12,600 lbs. Plus or Minus 3% Capacity: 80,000 lb. GVWR  
 102" Wide Lightweight 11,375 lbs. Plus or Minus 3% Capacity: 80,000 lb. GVWR

### Features:

- Mainframe..... 16" Fabricated main beams with 7/16" x 5" top flange, 1/2" x 5" bottom flange, 1/2" x 5" top flange, 5/8" x 5" bottom flange in the neck with 1/4" web (light-weight model 3/8" x 5" top and bottom flange, 3/8" x 5" top 1/2" x 5" bottom flange in the neck with 3/16" web) welded on both sides. All flange and web material is high strength steel.
- Crossmembers... 8" x 8.5# Structural channel.
- Kingpin..... 2" SAE kingpin, 3/8" kingpin plate, 20" kingpin setting (standard).
- Suspension..... Watson-Chalin® 50,000 Lb. 7 leaf single point spring suspension.
- Axles..... (2) 25,000 Lb., 5" round, 5/8" wall.
- Brakes..... 16-1/2" x 7", Type 30 brake chambers, outboard drums, Meritor WABCO® (2S/1M) ABS on one axle.
- Wheels..... 8.25 x 24.5, Steel 10 hole disc, hub piloted (color: white).
- Tires..... 11R x 24.5 Radials.
- Landing gear..... Winch back 5-1/2" pipe (for lightweight winch back 2" x 4" reinforced tubing)
- Finish..... Shotblasted and painted black with a high solid polyurethane paint.
- Floor..... None, 1/4" smooth plate over kingpin and tandem areas.
- Lights..... 7-Way main receptacle, sealed wiring harness, rubber mounted LED lights. 3 Lights per side including mid-turn.
- Tandem..... Set at 50" from the rear of the trailer.
- Tiedowns..... (6) Winches with (6) 4" flat hook nylon straps.
- Rear bumper..... Heavy duty pipe push bumper and high visibility reflective conspicuity tape.
- Uprights..... 5" x 5" x 3/8" Square tubing, 4" x 10" x 5/16" bunk (light-weight model: 5" x 5" x 1/4" square tubing, 4" x 10" x 1/4" bunk).

### Options:

- Straight frame without 4" drop center
- Additional trailer length (per foot)
- Airlift axle for single point or airride suspensions
- Watson-Chalin® air ride suspension
- HUTCH® three point suspension
- Vulcan® single point load cells (L03) mounted (830-00339)
- Vulcan® V-200 or V-500 trailer electronics (830-00340)
- Full width and full height front bulkhead
- Polished finish aluminum wheels (saves 175 lbs.)
- Machine finish aluminum wheels (saves 175 lbs.)
- Grapple bar

**Viking Specialized Trailers, L.L.C.**  
 1730 S.W. Stalling Dr., Suite 101  
 Nacogdoches, Texas 75964  
 (936) 564-8370 (844) 815-6210  
 Fax (936) 205-9171  
 www.vikingspztrailers.com