

**Built for Your**



**Industry**



(a subsidiary of Bright Coop, Inc.)

*built the way you want it for the way you use it!*

**35 Ton, "Hyd-Beavertail" Lowboy**  
**Model: VFDD49HB16F35T Weight 18,620 lbs. Plus or Minus 3%**



The 35 Ton Hydraulic Beavertail is designed for loading and unloading a variety of heavy equipment. The full width hydraulic apron raised and unfolds and provides a full width loading ramp surface allowing all types of wheel and track machines to be loaded and unloaded safely. Available with a hydraulic winch to assist in loading damaged and non working equipment. Popular in the equipment rental business the Viking 35 Ton is a must have to get the job done.  
Capacity: 88,000 lb. GVWR.



# Built for Your



# Industry



(a subsidiary of Bright Coop, Inc.)

*built the way you want it for the way you use it!*

## 35 Ton, "Hyd-Bevetail" Lowboy Model: VFDD49HB16F35T

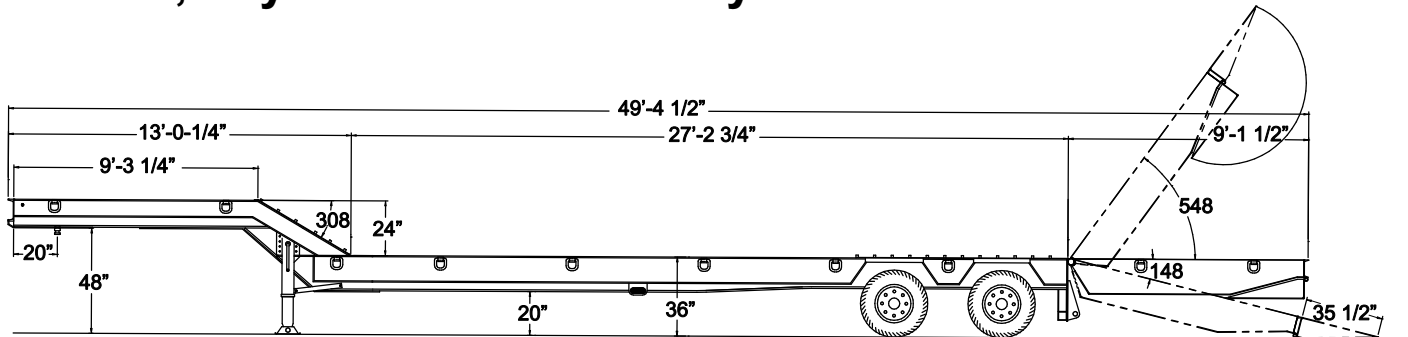

**102" Wide Weight 18,620 lbs. Plus or Minus 3% Capacity: 88,000 lb. GVWR**

### Features:

- Mainframe..... 16" Fabricated main beams, 1/2" x 6" top flange and 3/4" x 6" bottom flange with 1/4" web welded on both sides. All flange and web material is high strength steel.
- Crossmembers... 8" x 6.5# Jr. I beam on 20" centers.
- Kingpin..... 2" SAE kingpin, 3/8" kp plate, 84" swing clearance, 20" kingpin setting (standard).
- Siderails..... 12" x 20.7# Structural channel, 8" x 8.5# structural channel on the neck.
- Suspension..... Hendrickson® HT250US air ride suspension with manual dump valve.
- Axles ..... (2) 25,000 Lb., 5" round, 5/8" wall.
- Brakes..... 12-1/4" x 7-1/2", Type 30/30 brake chambers, outboard drums, Meritor WABCO® (2S/1M) ABS on one axle.
- Wheels..... 6.75 x 17.5, Steel 10 hole disc, stud piloted (color: white).
- Tires..... 235/75R x 17.5 Radials.
- Landing gear..... 2 Speed gear with 62,500 lb. lift capacity; 200,000 lb. static capacity (standard).
- Finish..... Shotblasted and painted with a high solid polyurethane paint. Colors: black or red (standard).
- Floor..... 2" Nominal oak (standard), 1/4" metal covering is standard over tandems areas, 1/4" metal covering with 1" traction bars on approach ramp to upper deck.
- Lights..... 7-Way main receptacle, sealed wiring harness, rubber mounted LED lights. 3 Lights per side including mid-turn.
- Tandem..... Set at 164" from the rear of the dovetail.
- Dovetail..... Hydraulic assisted 9 ft. ramp with 3 ft. fold under apron (12' overall) with approximate 14.5° degree approach angle, covered with 2" nominal oak.
- D-rings..... (18) Total (4) 1" on upper deck, (14) 1" on rear deck.

### Options:

- 15,000 Lb. hydraulic winch with 5/8" x 100' cable
- Hydraulic remote valve
- (2) Two remote ports and 12' remote cable for winch
- Weld on winches
- Fold out outriggers
- Width increase to 9ft
- Longer and shorter lengths
- Between the beam tool box
- Epoxy or zinc-rich primer available

**Viking Specialized Trailers, L.L.C.**  
1730 S.W. Stalling Dr., Suite 101  
Nacogdoches, Texas 75964  
(936) 564-8370 (844) 815-6210  
Fax (936) 205-9171  
[www.vikingspztrailers.com](http://www.vikingspztrailers.com)